

REV.	ECN NO	LOCATIONS	DESCRIPTION	DATE

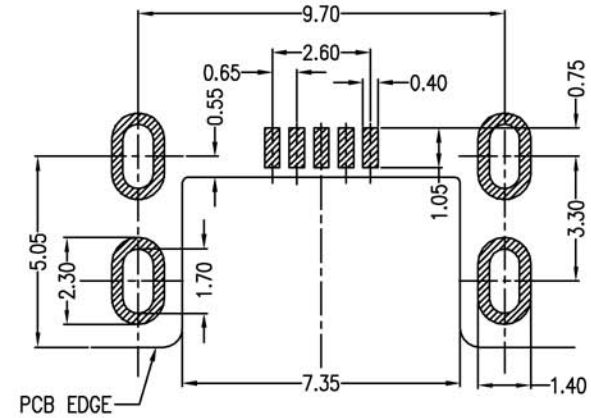
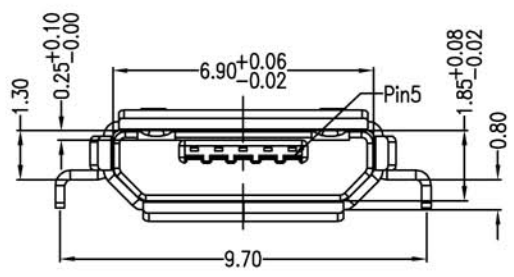
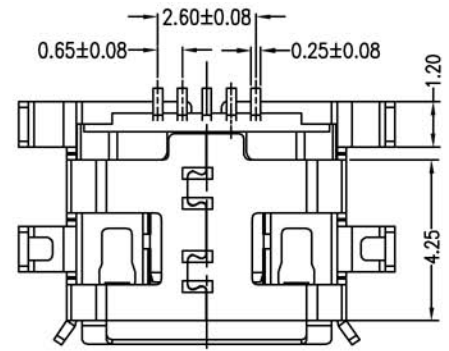
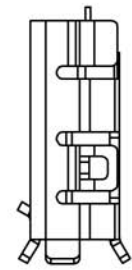
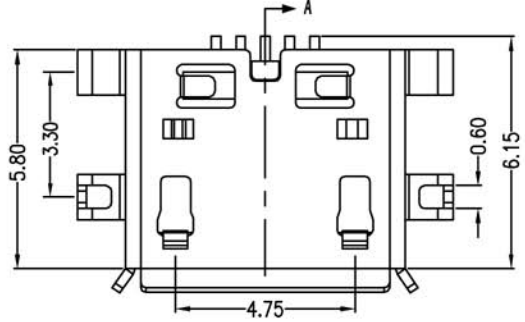
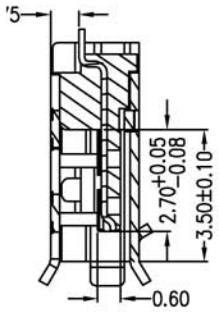
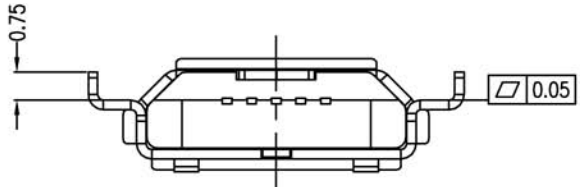

Note:
 1.Material:
 1.1 Housing: High temperature thermoplastic with g.f,UL94v-0
 1.2 Contact: copper alloy,t=0.15mm
 1.3 Shell: copper alloy,t=0.25mm
 2.Specification:
 2.1 Current rating: 1 A Max.
 2.2 Dielectric withstanding voltage: 100 V(ac) for 1 min.
 2.3 Contact resistance: 30 MΩ Max.
 2.4 Insulation resistance: 100 MΩ Min.
 2.5 Total mating force: 3.57 Kgf Max.
 2.6 Total unmating force: 1.0 Kgf Min.
 2.7 Temperature range: -30°C~80°C

A 01 S B 1 4 1 B 3-400

① ② ③ ④ ⑤ ⑥ ⑦ ⑧ ⑨ ⑩

- ① 产品代号 A:成品
- ② 产品系列 01:micro usb 5pin
- ③ 产品类别 S:母座
- ④ 产品类型 B:8 TYPE
- ⑤ 外壳材质 1:C2680R-1/2H
- ⑥ 端子材质 4:C5191R-EH
- ⑦ 主体材质 1:LCP
- ⑧ 主体颜色 B:黑色
- ⑨ 下板类型 3:沉板式
- ⑩ 细节序号 400 :Micro usb 5s B Type Smt沉板式0.8四脚全插有导位有孔双卡点

RECOMMENDED PCB LAYOUT
PCB图仅供参考

PART NO: A01SB141B3-400		MATERIAL: SEE NOTE		TITLE: Micro usb 5s B Type Smt沉板式0.8四脚全插有导位有孔双卡点	
MODEL NO: XX		FINISH: SEE NOTE			
UNIT: MM	SIZE: A4	COLOR: SEE NOTE		DWG NO: A400	
TOLERANCE UNSPECIFIED		DR: xiayouhong		REV: A	
.x 0.15		CHK:		SCALE: 5:1	
.xx 0.10		APP:		DATE: 2014.04.23	
.xxx 0.05					
Ang 1°					